

IT - ISTRUZIONI DI MONTAGGIO
EN - ASSEMBLY INSTRUCTIONS
DE - MONTAGEANLEITUNG
FR - INSTRUCTIONS DE MONTAGE

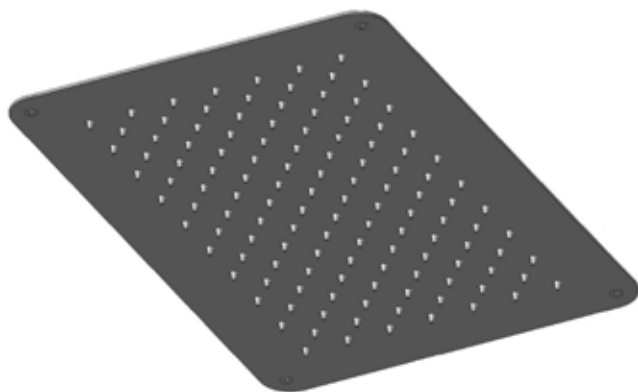

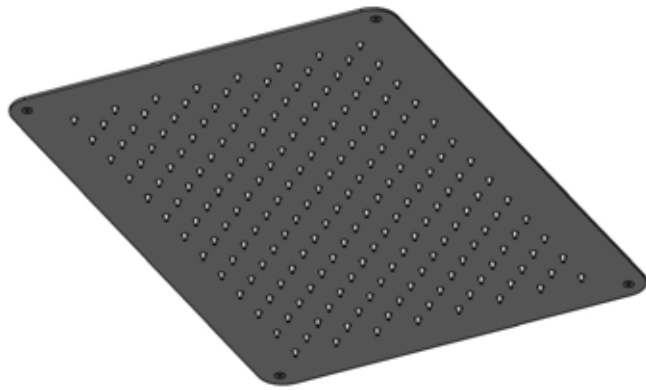

MIN 1 Bar
MAX 5 Bar
BEST 3 Bar

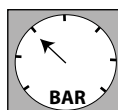
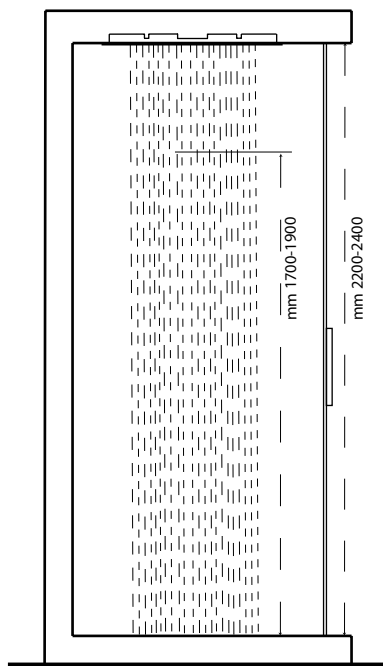
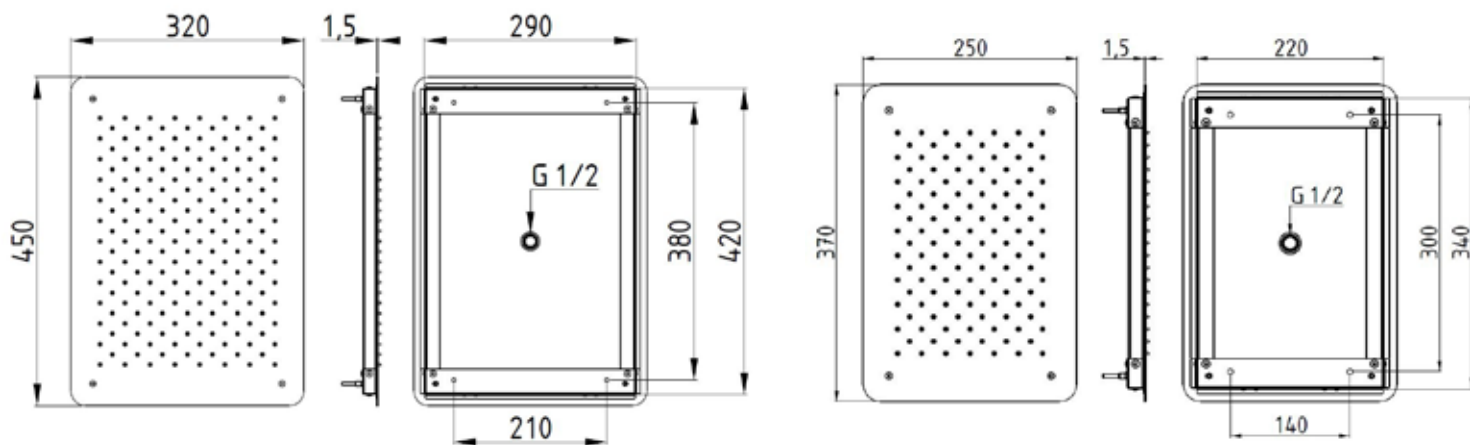

MAX 70°C
BEST 38/40°C

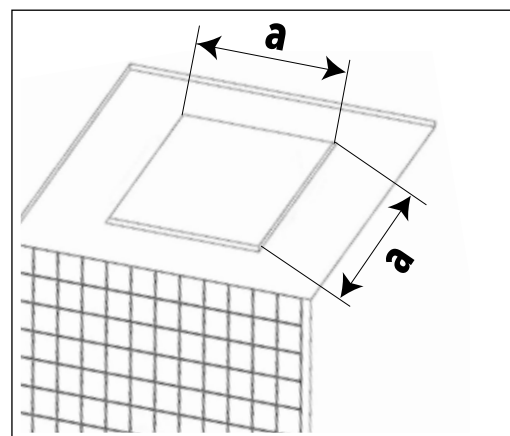

IT-Dimensioni sede soffitto EN-Ceiling seat dimensions DE-Deckenabmessungen FR-Dimensions du siège au plafond	Min. (mm)	Max. (mm)
450x320	420x290	425x295
370x250	340x220	345x225

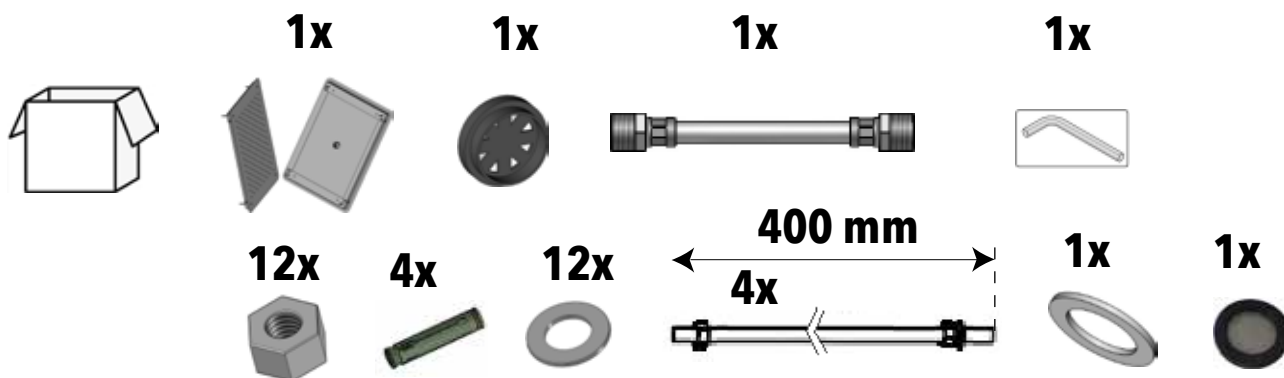

IT - L'apparechio deve essere installato da personale abilitato ai sensi e per l'effetto delle leggi in vigore.

EN - According to the law, all installation and maintenance operations require a qualified person.

DE - Das Gerät muss von qualifiziertem Personal gemäß den geltenden Gesetzen installiert werden.

FR - L'appareil doit être installé par du personnel qualifié conformément et pour l'effet des lois en vigueur.

1

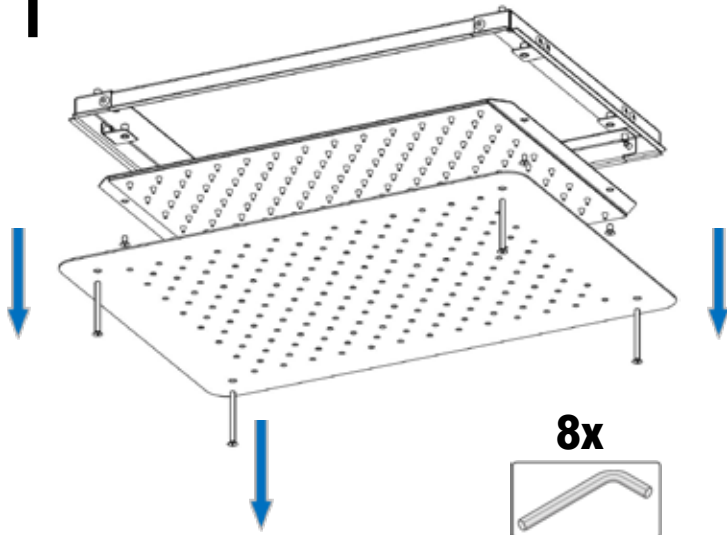

8x
Ch. 2.5 mm



2

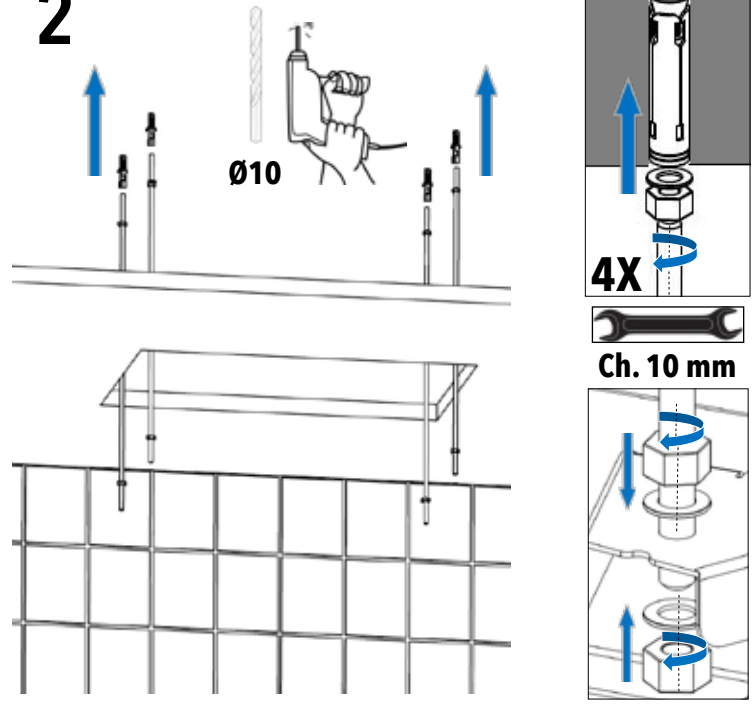

IT-Telaio allineato al soffitto
EN-Align frame to ceiling
DE-Rahmen aus der Decke ausgerichtet
FR-Installez le cadre bien aligné au plafond

3

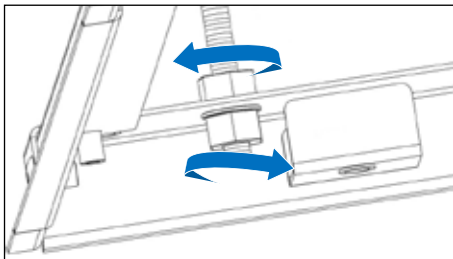
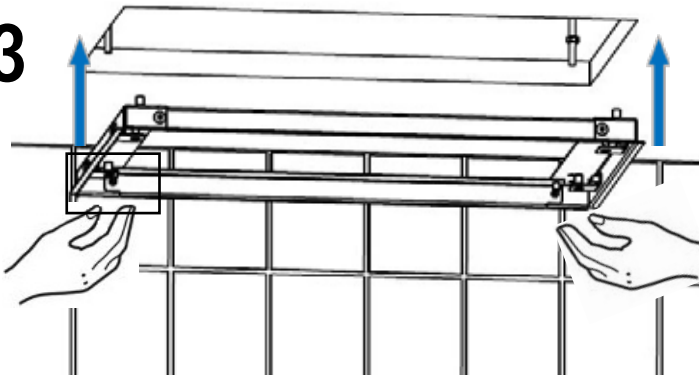

Ch. 10 mm

4

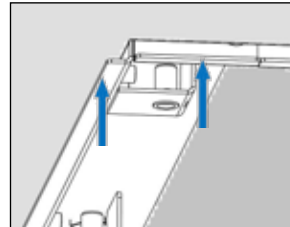
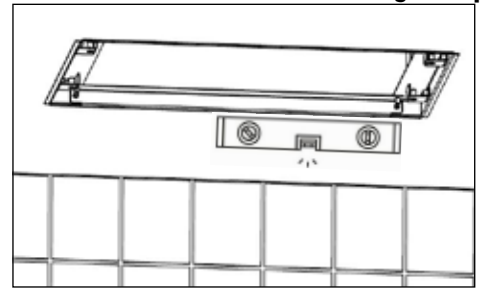

IT-Battuta del telaio
EN-Frame stop
DE-Rahmenstopp
FR-Arrêt de cadre

5

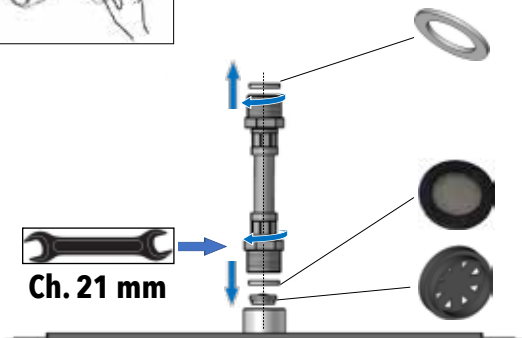
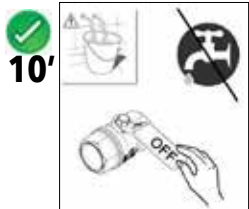

Ch. 21 mm

6

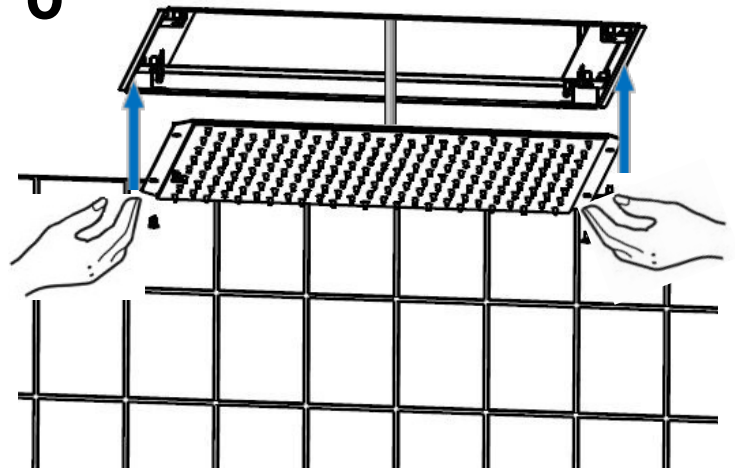

4x
Ch. 2.5 mm

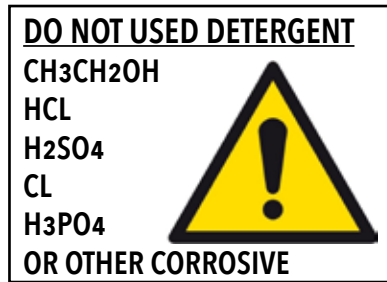
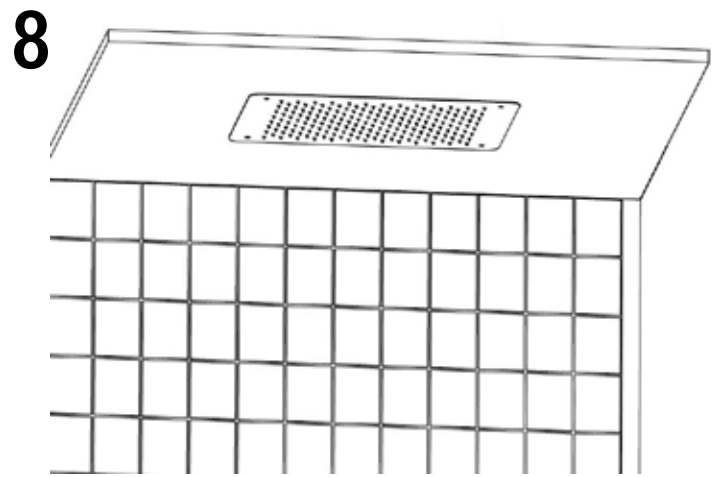
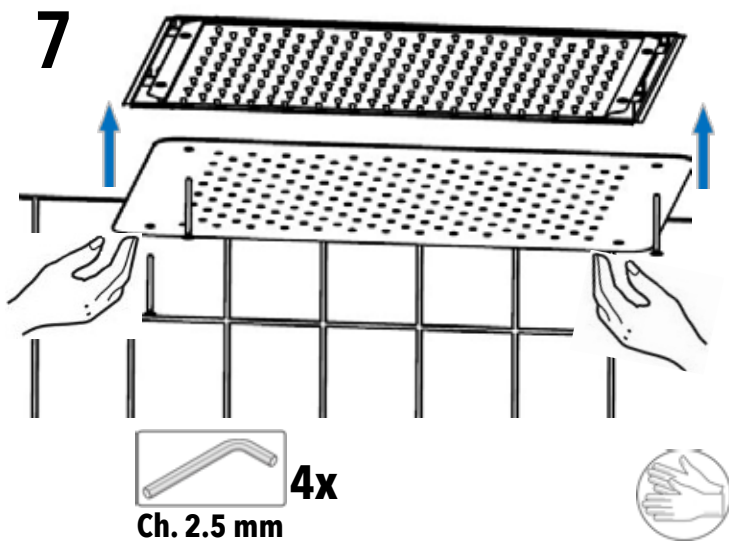

IT - LA GARANZIA DEL PRODOTTO NON COPRE

L'utilizzo improprio.
 L'errata predisposizione dell'impianto idraulico.
 Danni causati da depositi di calcare o altre impurità.
 Detergenti non adatti.

EN - NOT COVERED BY PRODUCT CARE

Not correct use.
 Incorrect setup of the hydraulic system.
 Water impurities or limestone deposits.
 Improper detergents.

DE - DIE PRODUKTGARANTIE GILT NICHT

Die falsche Verwendung
 Die falsche Anordnung des Hydrauliksystems.
 Schäden durch Kalkablagerungen oder andere Verunreinigungen.
 Ungeeignete Reiniger.

FR - LA GARANTIE DU PRODUIT NE COUVRE PAS

Utilisation incorrecte.
 La mauvaise disposition du système hydraulique.
 Dommages causés par des dépôts de calcaire ou d'autres impuretés.
 Nettoyants inappropriés.

IT - DUE ANNI DI GARANZIA DEL PRODOTTO

Contro i difetti o vizi di fabbricazione.

EN - TWO-YEAR PRODUCT CARE

Against defects of fabrication.

DE - ZWEI JAHRE LANG PRODUKTGARANTIE

Gegen Mängel oder Herstellungsfehler

FR - GARANTIE DE PRODUITS DE DEUX ANSO

Contre les défauts de fabrication.

IT - ATTENZIONE: Si declina ogni responsabilità relativa ad eventuali inesattezze contenute in queste istruzioni dovute ad errori di trascrizione.

EN - WARNING: We decline all responsibility for eventual inaccuracy contained in the instructions due to transcript errors.

DE - ACHTUNG: Wir lehnen jede Verantwortung für Ungenauigkeiten in diesen Anleitung aufgrund von Transkriptionsfehlern ab.

FR - ATTENTION: Nous déclinons toute responsabilité pour toute inexactitude contenue dans ces instructions en raison d'erreurs de transcription.